

Sunbeam

MASTER
SERIES

PB8100

Soup & Smoothie Blender

User Guide



Contents

Sunbeam's Safety Precautions	1
Features of your Soup & Smoothie Blender	3
Using your Soup & Smoothie Blender	5
Auto Modes	6
Expert or Manual Mode	10
Care and Cleaning	11
Troubleshooting	12
Recipes	13

Important instructions – retain for future use.

تأكد من تفهم احتياطات السلامة المذكورة اعلاه

請務必理解上述的安全預防措施。

Assurez-vous que les précautions ci-dessus relatives à la sécurité sont bien comprises

Versichern Sie sich, dass die obenstehenden Sicherheitsmaßnahmen Verstanden werden

Βεβαιώστε πως οι παραπάνω προφυλάξεις ασφαλείας γίνονται κατανοητές

Pastikan bahwa tindakan-tindakan keselamatan seperti di atas dimengerti anda

Accertatevi che le suddette norme di sicurezza siano comprese a dovere

上記の注意事項をよくお読みになり、安全を御確認ください

Уверете се дека погоре споменатите мерки на претпазливост се добро разбрани

Asegúrese de que las precauciones de seguridad precedentes sean bien comprendidas

کاری یکنید که احتیاط‌های بالا حتماً درک بشوند

ต้องแน่ใจว่า ข้อควรระวังเรื่องความปลอดภัยข้างต้น เป็นที่เข้าใจกันดี

Yukarda belirtilen güvenlik önlemlerinin anlaşıldığından emin olunuz

Xin kiểm chắc rằng những biện pháp làm an toàn kể trên được hiểu rõ

Sunbeam's Safety Precautions

SAFETY PRECAUTIONS FOR YOUR SOUP & SMOOTHIE PB8100 BLENDER.

- Always operate on a flat level surface.
- Ensure the control dial is “OFF” and the jug is in place before plugging into the power outlet.
- Always remove the plug from the power outlet when the blender is not in use, before disassembling, putting on or taking off parts, and before cleaning other than washing the jug.
- Do not use appliance for other than intended household use.
- Do not let cord hang over the edge of table or counter or touch hot surface.
- Blade is sharp, handle carefully.
- Ensure fingers are kept well away from the blades when in use.
- Be careful when handling the sharp cutting blades, emptying the bowl and during cleaning.
- Always operate the blender with the lid in place.
- The blender is fitted with a safety switch to prevent the motor operating unless the lid is in place.
- Lift and open the lid or removable measuring cup carefully to avoid high temperature steam.
- The maximum load capacity of the jug is 1.75 litres
- This appliance shall not be used by children. Keep the appliance and its cord out of reach of children.
- Never move your appliance if it contains anything hot.
- The glass bowl contains hot liquid, pour it out carefully.
- Be careful if hot liquid is poured into the blender as it can be ejected out of the appliance due to a sudden steaming.
- Switch off the appliance and disconnect from supply before changing accessories or approaching parts that move in use.
- Do not touch surfaces of steam compartments. It is hot.
- Do not operate the appliance near wall or cabinet to prevent damage from steam.
- Do not operate the appliance (heating, blending functions or programmes) when the bowl is empty.
- Do not immerse in water or put it in the dishwasher.
- Do not remove the measuring cup or add ingredients when the appliance is blending.
- Do not insert a spatula or spoon by the hole of the measuring cup on the lid, during a heating or blending cycle.
- Do not add cool or cold water in the bowl after a warm cycle, to avoid thermal shock.
- Do not use chemical descaler or coffee machine descaler on the bowl non stick-heating plate.
- The temperature of accessible surfaces is high when the appliance is operating. Do not touch the surfaces of marked with this symbol during use. It is hot!

Sunbeam's Safety Precautions

Sunbeam is very safety conscious when designing and manufacturing consumer products, but it is essential that the product user also exercise care when using an electrical appliance. Listed below are precautions which are essential for the safe use of an electrical appliance:

- Read carefully and save all the instructions provided with an appliance.
- Always turn the power off at the power outlet before you insert or remove a plug. Remove by grasping the plug - do not pull on the cord.
- Turn the power off and remove the plug when the appliance unattended, before assembling, disassembling or cleaning.
- Do not use your appliance with an extension cord unless this cord has been checked and tested by a qualified technician or service person.
- Always use your appliance from a power outlet of the voltage (A.C. only) marked on the appliance.
- This appliance is not intended for use by persons (including children) with reduced physical, sensory or mental capabilities, or lack of experience and knowledge, unless they have been given supervision or instruction concerning use of the appliance by a person responsible for their safety.
- Children should be supervised to ensure that they do not play with the appliance.
- The temperature of accessible surfaces may be high when the appliance is operating.
- Never leave an appliance unattended while in use.
- Do not use an appliance for any purpose other than its intended use.
- Do not place an appliance on or near a hot gas flame, electric element or on a heated oven.
- Do not place on top of any other appliance.
- Do not let the power cord of an appliance hang over the edge of a table or bench top or touch any hot surface.
- Do not operate any electrical appliance with a damaged cord or after the appliance has been damaged in any manner. If damage is suspected, return the appliance to the nearest Sunbeam Appointed Service Centre for examination, repair or adjustment.
- For additional protection, Sunbeam recommend the use of a residual current device (RCD) with a tripping current not exceeding 30mA in the electrical circuit supplying power to your appliances.
- Do not immerse the appliance in water or any other liquid unless recommended.
- Appliances are not intended to be operated by means of an external timer or separate remote control system.
- This appliance is intended to be used in household and similar applications such as: staff kitchen areas in shops, offices and other working environments; farm houses; by clients in hotels, motels and other residential type environments; bed and breakfast type environments.

If you have any concerns regarding the performance and use of your appliance, please visit www.sunbeam.com.au or contact the Sunbeam Consumer Service Line.

Ensure the above safety precautions are understood.

Features of your Soup & Smoothie Blender

Removable measuring cup

Allows steam to be released, or add ingredients during blending.

Lid

Lid must be attached to operate the blender.

Glass Jug

The glass jug allows you to monitor ingredients & blending process.

Blade

Non-stick heating plate

On/Off button

Control panel

The control panel illuminates once the blender is powered On.

Cord storage

Non-slip rubber feet

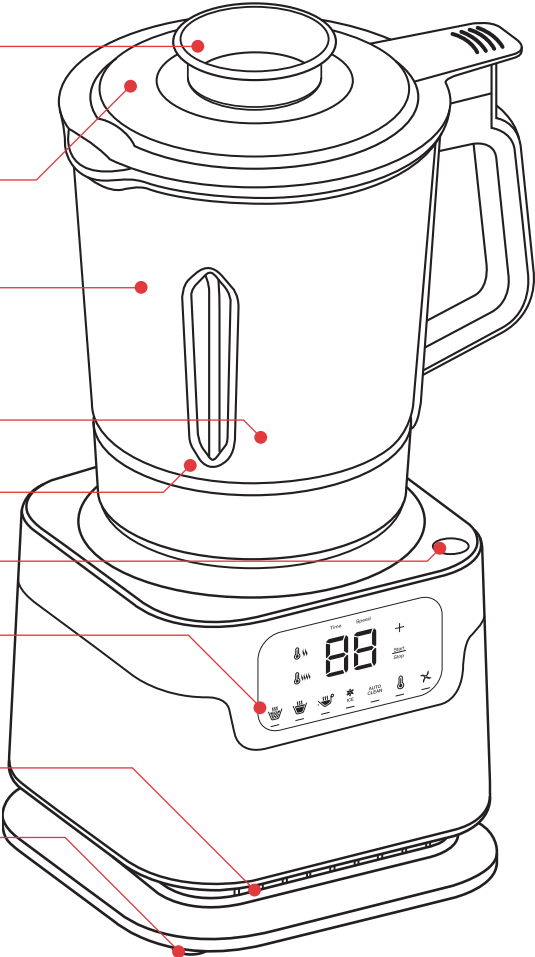

Features of your Soup & Smoothie Blender continued

Control Panel

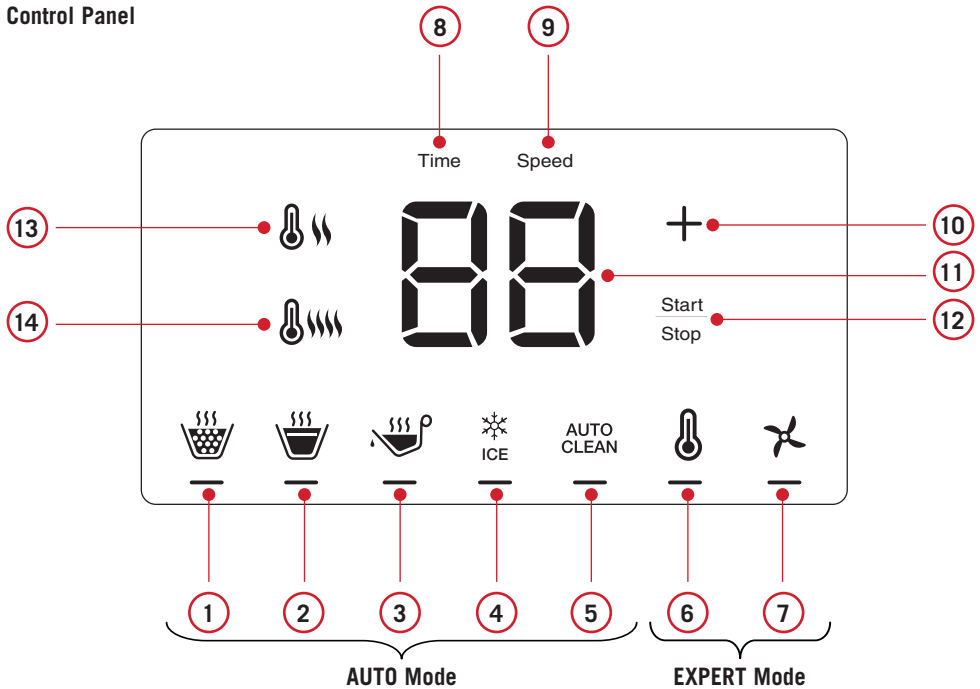

AUTO Mode

1. Chunky/Thick soup
2. Veloute/Fine soup
3. Sauce key
4. Ice crushing/Smoothie
5. Auto clean key
8. Time indicator
9. Speed indicator
10. Increase or decrease
11. Display
12. Start/Stop
13. Low temperature indicator
14. High temperature indicator

EXPERT Mode

6. Temperature set
7. Blend key

Using your Soup & Smoothie Blender

BEFORE USING FOR THE FIRST TIME

1. Remove the appliance and all accessories from the packaging.
2. Peel off any labels, point of sale and the protection cover on control panel of the blender.
3. Thoroughly clean the parts which come into contact with food before using the blender for the first time. Dry thoroughly before assembling.

USING YOUR SOUP & SMOOTHIE BLENDER

1. Place the blender on a firm, stable & flat surface, allowing sufficient ventilation.
2. Place ingredients inside the glass jug
3. Place the lid on the glass jug and press it down firmly & properly.
4. Place the measuring cup into the opening on the lid.
5. Position the glass jug on to the motor base housing unit by using guided grooves and make sure glass jug fits properly on motor base housing unit.

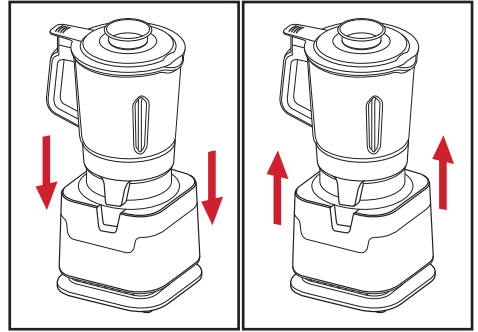
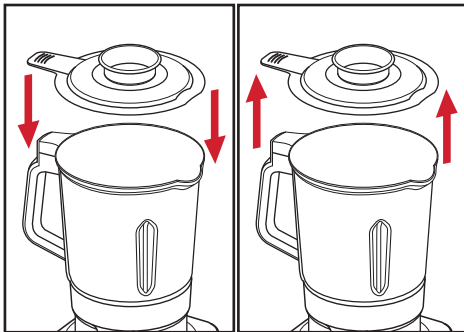

6. Connect the appliance to a suitable mains supply outlet.
7. Press the ON/OFF button to turn on the blender and the display panel.
8. Select the desired programme and start the process by pressing Start/Stop button.

WARNING: Do not touch the bottom of glass jug and glass jug during cooking, as it becomes very hot.

If the glass jug contains hot liquid, pour it out carefully.

Note:

1. During the programme, press Start/Stop button to pause the process. Re-press the Start/Stop button again and the programme continues.
2. After completion of the programme, if no button is pressed for 10 minutes the appliance will shut down automatically.
3. To turn off the appliance at any time, press ON/OFF button.
9. At the end of the programme the LCD displays "00" and the appliance will sound an alert (5 beeps).
10. Disconnect the appliance from mains supply and let it to cool down completely once finished cooking.

AUTO MODES (5 Automatic programmes)

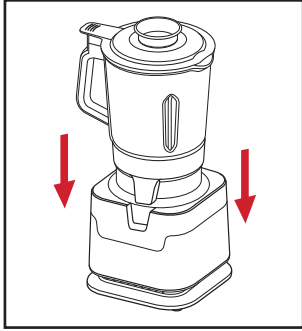

1. Place the jug on base unit.

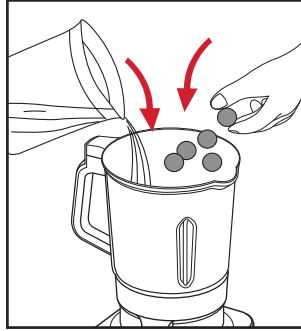

2. Put in ingredients and liquid.

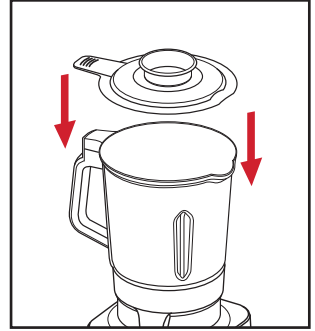

3. Add lid.

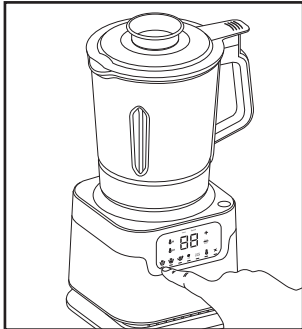

4. Select the programme.

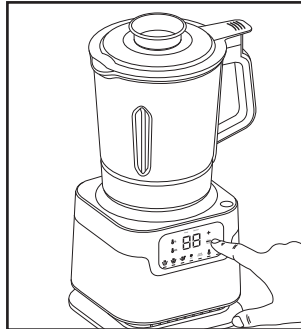

5. Start the programme.

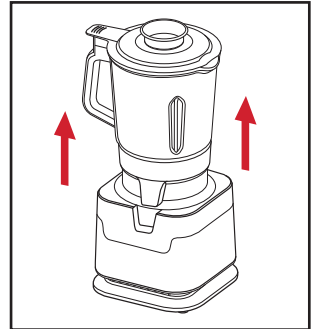

6. Lift up the jug after finished.

AUTO MODES (5 Automatic programmes) continued



CHUNKY / THICK SOUP

(Semi blended soup)

1. Place the blender base on a firm, stable & flat surface.
2. Assemble the glass jug correctly and plug in the appliance to a suitable main supply outlet.
3. Place the ingredients into the glass jug and add liquid as per your desired recipe, replace the lid.
4. Press the ON/OFF button. The control panel will turn on, and go into 'standby' mode.

Note: The Maximum fill for hot ingredients is 1400ml. During the cooking process, you can add more ingredients by lifting the measuring cup and dropping them through the opening in the lid.

5. Press the  to select the Chunky Soup programme. The selected programme is highlighted and the Start/Stop button will flash.
6. Press the **Start/Stop** to start the process. The **Start/Stop** will stop flashing and the colour will change from white to red.
7. The cooking time will count down during the cooking & blending process.
8. The appliance will begin cooking the ingredients in a few minutes.
The appliance will then automatically start to occasionally stir ingredients.

Note: During the cooking process, you can stir at any time by pressing  on control panel.

9. After stirring, the appliance will continue the cooking process.
10. At the last minute of the programme, the appliance will automatically start to blend the ingredients until the end of the programme.

11. Once the cooking time has ended the appliance will sound an alert (5 beeps), then it will automatically switch to keep warm mode and the LCD will display

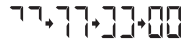

12. Your soup will keep warm at a low temperature for 20 minutes.
13. After 20 minutes on the keep warm function, the appliance will sound an alert (5 beeps) and then it will automatically go into standby mode.



VELOUTÉ / FINE SOUP FUNCTION



(Fully blended soup)

1. Place the blender base on a firm, stable & flat surface.
2. Assemble the glass jug correctly and plug in the appliance to a suitable main supply outlet.
3. Place the ingredients into the glass jug and add liquid as per your desired recipe, replace the lid.
4. Press the ON/OFF button. The control panel will turn on, and go into 'standby' mode.

Note: The Maximum fill for hot ingredients is 1400ml. During the cooking process, you can add more ingredients by lifting the measuring cup and dropping them through the opening in the lid.

5. Press the  to select the Fine Soup programme. The selected programme is highlighted and the Start/Stop button will flash.
6. Press the Start/Stop to start the process. The Start/Stop will stop flashing and the colour will change from white to red.
7. The cooking time will count down during the cooking & blending process.

AUTO MODES (5 Automatic programmes) continued

8. The appliance will begin cooking the ingredients in a few minutes.
The appliance will then automatically start to occasionally stir ingredients.
- Note: During the cooking process, you can stir at any time by pressing  on control panel.**
9. After stirring, the appliance will continue the cooking process.
 10. At the last minute of the programme, the appliance will automatically start to blend the ingredients until the end of the programme.
 11. Once the cooking time has ended the appliance will sound an alert (5 beeps), then it will automatically switch to keep warm mode and the LCD will display 
 12. Your soup will keep warm at a low temperature for 20 minutes.
 13. After 20 minutes on the keep warm function, the appliance will sound an alert (5 beeps) and then it will automatically go into standby mode.



SAUCE FUNCTION (Fully blended sauce)

1. Place the blender base on a firm, stable & flat surface.
2. Assemble the glass jug correctly and plug in the appliance to a suitable main supply outlet.
3. Place the ingredients into the glass jug and add liquid as per your desired recipe, replace the lid.
4. Press the ON/OFF button. The control panel will turn on, and go into 'standby' mode.

Note: The Maximum fill for hot ingredients is 1400ml. During the cooking process, you can

add more ingredients by lifting the measuring cup and dropping them through the opening in the lid.

5. Press the  to select the Sauce Function programme. The selected programme is highlighted and the Start/Stop button will flash.
6. Press the Start/Stop to start the process. The Start/Stop will stop flashing and the colour will change from white to red.
7. The cooking time will count down during the cooking & blending process.
8. The appliance will begin cooking the ingredients in a few minutes.
The appliance will then automatically start to occasionally stir ingredients.

Note: During the cooking process, you can stir at any time by pressing  on control panel.

9. After stirring, the appliance will continue the cooking process.

Note: In Auto mode, the time duration and blending speed will be automatically selected according to below table.

Programme	Cooking Time	Keep warm	Blending
CHUNKY/ THICK SOUP	30mins	20mins	Medium Speed
VELOUTÉ/ FINE SOUP	30mins	20mins	High Speed
SAUCE	20mins	---	Low Speed

AUTO MODES (5 Automatic programmes) continued



ICE

BLENDING COLD INGREDIENTS

ICE CRUSHING/SMOOTHIE FUNCTION

1. Place the blender base on a firm, stable & flat surface.
2. Place the glass jug onto base unit and plug in the appliance to suitable main supply outlet.
3. Fill the glass jug with all necessary ingredients or ice cubes and replace the lid.
4. Press the ON/OFF button. The control panel will turn on, and go into 'standby' mode.

Note: The maximum fill for cold ingredients/ice cubes is 1750ml.





5. Press  then Start/Stop key to start the process.
6. In this mode, the blades rotate at a high speed alternatively, for up to 1 minute.
7. The appliance will sound an alert (5 beeps) to indicate the crushing/smoothie process is completed.

EXPERT OR MANUAL MODE



COOKING FUNCTION

MAKING SOUP

1. Place the base housing unit on a firm, stable & flat surface.
2. Assemble the glass jug correctly and plug in the appliance to a suitable main supply outlet.
3. Put the ingredients into the glass jug and add liquid, then replace the lid.
4. Press the ON/OFF button. The control panel will turn on, and go into 'standby' mode.
5. Press  on control panel. By default the high temperature  will be selected.
6. A default cooking time of 30 minutes will be selected.
7. To change the cooking temperature press 
 - low temperature (75°C~85°C) 
 - high temperature (90°C~100°C) 
8. Adjust the cooking time by using **+** from 1 minute to 60 minutes. The default setting is 30 minutes.

Note: Holding down the **+ will increase the time at a faster rate.**

9. After selecting the cooking temperature and cooking time, select **Start/Stop** to start the process.

Note: During the cooking process, you can stir at any time by pressing  on control panel.



10. Once the cooking time has ended the appliance will sound an alert (5 beeps), then it will automatically switch to keep warm mode and the LCD displays , which will keep your ingredients at low temperature for 20 minutes.

11. After 20 minutes of the keep warm function, the appliance will sound an alert (5 beeps) and then it will automatically switch into standby mode.

Note: The maximum load capacity for making soup is 1.4L.

BLENDING FUNCTION

BLENDING/MIXING

1. To blend the ingredients according to your preference, press the  on control panel. The default setting, Medium (2) speed, will be selected.
2. Press **+** to adjust the speed of the blending function.
3. In the blending mode, it is possible to select three different speeds. LOW (1), MEDIUM (2) or HIGH (3).
4. Place the ingredients into glass jug, attach the lid, ensuring it fits properly.
5. Once the blending speed is selected, press  to start blending. If you keep the finger on this key, the blending will continue. When you remove your finger, blending will stop.

Note: For safety reasons, the blending function in manual operation will stop automatically after few seconds.

Note: The maximum load capacity for making soup is 1.75L.

Care and Cleaning

AUTO CLEAN FUNCTION

1. Never immerse the base, glass jug, power cord or mains plug into water.
2. Fill the glass bowl with 1200ml of water with 3 or 4 drops of washing-up liquid.
3. Rinse inside of the bowl using the cleaning brush, to remove residue sticking on glass jug.
4. Wash the lid in water with washing up liquid and rinse it using the cleaning brush, then cover the glass jug with the lid.
5. Select auto cleaning function by pressing the **AUTO CLEAN** on control panel.
6. Press Start/Stop key to start the cleaning process.
7. The appliance will start to blend the liquid at the beginning of the cleaning process, and it will heat the water for up to 2 minutes. Blending will then commence to help release any food that may be on the underside of the blades.
8. Once the programme is complete, unplug the appliance.
9. Lift the glass jug from base housing unit and place it on flat surface.
10. Remove the lid and finish cleaning the glass bowl with a sponge, and dry them thoroughly.
11. Clean the base housing unit with moist damp soft cloth.

Note: This function will facilitate the cleaning of the glass jug.

Warning:

1. **Do not clean glass jug, interface and base housing with abrasive side of a sponge or pad, only use a soft or damp cloth to clean.**
2. **Do not use any harsh abrasives or strong household cleaners or any abrasive tools as these may damage the non-stick coating surface.**
3. **Handle the blades inside the glass jug carefully when cleaning them; they are very sharp.**
4. **Do not put the glass jug in the dishwasher.**

Troubleshooting

Problem	Possible Cause	Solution
The appliance does not work.	The appliance is not plugged in.	Check the appliance mains plug is connected in the socket properly.
	The glass jug is not placed on base unit.	Place the glass jug properly with guided grooves on the base unit.
	The lid is not placed/fitted well onto the glass jug.	Place a lid properly onto the glass jug and make sure it fits properly.
No response or the sensitivity of control panel is getting low by pressing several times on function keys.	Appliance is under Electromagnetic Interference.	Unplug the appliance from power socket. Restart after few minutes.
	Dirt on control panel.	Clean the panel with soft cloth.
The ingredients have not blended well.	The ingredients exceeded the Max indication in the glass jug.	Remove some of the ingredients and ensure the ingredients are placed evenly over the bottom of the glass jug.
	The water or cooking liquid is not enough to blend well.	Make sure the water/liquid level is correct as mentioned in the recipe booklet.
The food is burnt.	Selected wrong program.	Select another program (Refer the Recipe booklet).
	The water or cooking liquid is not enough.	Make sure the water/cooking liquid level is correct as mentioned in the recipe booklet.

Recipen

THAI PUMPKIN SOUP

Serves 4 to 6

1kg butternut pumpkin, peeled, cut into 2cm pieces

2 tablespoons red curry paste

1¼ cups coconut cream

¼ cup fresh coriander, roughly chopped

Salt and freshly ground black pepper, to taste

1. Place all ingredients into the jug and secure lid.

2. Select VELOUTE function on the soup maker. Press START.

3. When soup has finished season with salt and pepper. Serve.

NOTE: If you prefer a smoother soup press the PUREE button until desired consistency is reached.

POTATO AND LEEK SOUP

Serves 4 to 6

2 tablespoons olive oil

1 leek, trimmed, finely sliced

2 cloves garlic, sliced

500g potatoes, peeled, roughly chopped

3½ cups chicken stock

1½ cups thickened cream

Fresh chives, to serve

Salt and freshly ground black pepper, to taste

1. Add all of the ingredients into the jug, except the chives, and secure lid.

2. Select the VELOUTE soup function. Press START.

3. When the soup is finished, season to taste with salt and pepper. Serve with fresh chives.

NOTE: If you prefer a smoother soup press the PUREE button until desired consistency is reached.

Recipes - continued

TOMATO BASIL SOUP

Serves 4 to 6

- 1kg vine-ripened tomatoes, halved length ways
- 3 cloves garlic, peeled, sliced
- 1 tablespoons olive oil
- 1 cup fresh basil leaves
- 1 large brown onion, quartered
- 1/3 cup tomato paste
- 2 cups chicken stock
- Salt and freshly ground black pepper, to taste

1. Preheat oven to 180°C. Line a tray with baking paper.
2. Place tomatoes and garlic on to the prepared tray. Drizzle with the oil and season with salt and pepper.
3. Roast for 40 minutes or until tomatoes are tender. Set aside to cool slightly.
4. Place all ingredients into the soup jug and secure lid.
5. Select the VELOUTE soup function. Press START.
6. When soup is finished, season to taste with salt and pepper. Serve.

NOTE: If you prefer a smoother soup press the PUREE button until desired consistency is reached.

MINISTRONE SOUP

Serves 4 to 6

- 2 carrots, peeled, chopped
- 2 celery stalks, sliced
- 2 cloves garlic, sliced
- 1 leek, sliced
- 1 zucchini, sliced
- 400g canned chopped tomatoes
- 3 1/2 cups vegetable stock
- 1 tablespoon tomato paste
- 200g potatoes, peeled, cut into 1cm cubes
- 1 cup spinach, roughly chopped
- 1/3 cup macaroni pasta

Salt and freshly ground black pepper, to taste
Basil pesto and grated parmesan cheese, to serve

1. Add the carrots, celery, garlic, leek, zucchini, tomato, stock and tomato paste into the jug and secure lid.
2. Select the CHUNKY soup function. Press START.
3. After 10 minutes of cooking, add the potatoes, spinach and pasta through the hole in the lid.
4. When the soup is finished, season to taste with salt and pepper. Serve with pesto and grated parmesan cheese.

Recipes - continued

MOROCCAN SPICED LENTIL SOUP

Serves 4 to 6

- 1 onion, quartered
 - 1 celery stalk, chopped
 - 1 carrot, peeled and chopped
 - 3 garlic cloves, sliced
 - 2 teaspoons ground coriander
 - 1 teaspoon ground cumin
 - 1 teaspoon ground turmeric
 - ½ teaspoon sweet paprika
 - ¼ teaspoon ground cinnamon
 - ½ teaspoon sea salt
 - 4 cups vegetable stock
 - 410g can crushed tomatoes
 - 1 cup red lentils, washed and rinsed until water runs clean
 - 1 lemon, juiced
 - Pinch of chilli flakes
 - 4 tablespoons fresh flat-leaf parsley, chopped
 - 1 tablespoon fresh coriander, chopped
 - Salt and freshly ground black pepper, to taste
1. Add all of the ingredients into the jug, except parsley and coriander, and secure lid.
 2. Select the CHUNKY soup function. Press START.
 3. When the soup is finished, season to taste with salt and pepper. Serve with parsley and coriander.

NOTE: If you prefer a smoother soup press the PUREE button until desired consistency is reached.

CREAMY CORN CHOWDER

Serves 4 to 6

- 200g chicken breast, finely sliced
 - 2 slices bacon, finely chopped
 - ½ red capsicum, seeds removed, diced
 - 1 onion, diced
 - 1 jalapeno, seeded for less heat if desired, finely chopped
 - 2 cloves garlic, sliced
 - 3 cups chicken stock
 - 200g potatoes, peeled, diced
 - Salt and freshly ground black pepper, to taste
 - 1 cups fresh or frozen corn
 - ½ cup thickened cream
 - Salt and freshly ground black pepper, to taste
 - Finely sliced shallots, to serve
1. Add all of the ingredients into the jug, except the shallots, and secure the lid.
 2. Select the CHUNKY soup function. Press START.
 3. When the soup is finished, season to taste with salt and pepper. Serve with shallots.
- NOTE:** If you prefer a smoother soup press the PUREE button until desired consistency is reached.

Recipes - continued

HOLLANDAISE SAUCE

Makes: 1.5 Litres

6 egg yolks

2 tablespoons lemon juice

1 teaspoon Tabasco or other hot sauce

½ teaspoon Dijon mustard

250g butter, chopped

Salt and freshly ground black pepper, to taste

1. Place egg yolks, lemon juice, Tabasco and Dijon mustard into the jug and secure the lid.
2. Select the SAUCE function. Press START.
3. After 5 minutes, add the butter through the hole in the lid.
4. When the sauce is finished, season to taste with salt and pepper. Serve immediately.

CREAM ANALGISE

Makes: 1 Litre

5 egg yolks

1 cup milk

1 cup thickened cream

½ cup caster sugar

1 teaspoon vanilla extract

1. Place all ingredients into the jug and secure the lid.
2. Select the SAUCE function. Press START.
3. Serve.

CHOCOLATE GANACHE

Makes: 1½ cups

300g chocolate (milk, white or dark), broken into pieces

¾ cup thickened cream

1. Place all ingredients into the jug and secure the lid.
2. Select the SAUCE function. Press START.
3. Serve.

TOMATO AND BASIL SAUCE

Makes: 5 cups

800g vine-ripened tomatoes, quartered

3 garlic cloves, thinly sliced

1 red onion, quartered

¼ cup fresh basil leaves, torn

1 tablespoon fresh oregano leaves

1 tablespoon fresh thyme leaves

1 teaspoon caster sugar

½ teaspoon chilli flakes

Salt and freshly ground black pepper, to taste

1. Place all ingredients into the jug and secure the lid.
2. Select the SAUCE function. Press START.
3. Season to taste with salt and pepper. Serve.

Recipes - continued

SATAY SAUCE

Makes: 2½ cups

- 1 garlic clove, sliced
 - 1 red chilli, sliced
 - 2 cups unsalted peanuts
 - 1¾ cups coconut milk
 - 2 tablespoons soy sauce
 - 1 tablespoon brown sugar
 - 1 tablespoon kecapmanis (sweet soy sauce)
1. Place all ingredients into the jug and secure the lid. Select the SAUCE function. Press START.
 2. Season to taste with salt and pepper. Serve.

MUSHROOM SAUCE

Makes: 2 cups

- 300g button mushrooms
 - 2 cloves of garlic, thinly sliced
 - 1½ cups thickened cream
 - 1 tablespoon olive oil or butter
- Salt and freshly ground black pepper, to taste
1. Place all ingredients into the jug and secure the lid. Select the SAUCE function. Press START.
 2. Season to taste with salt and pepper. Serve.

GREEN SMOOTHIE

Makes: 1 serving

- 1 banana, peeled
 - ½ red grapefruit, peeled, roughly chopped
 - ¼ avocado, skin and stone removed
 - 1 cup baby spinach
 - ½ cup ice
 - ½ cup water
 - 1 teaspoon freshly grated ginger
1. Place all ingredients into the jug and secure the lid.
 2. Place onto speed HIGH. Process for 30 seconds or until smooth.
 3. Serve in tall glass.

BREAKFAST SMOOTHIE

Makes: 1 serving

- 2 peaches, stones removed
 - 1 cup milk
 - ½ cup rolled oats
 - 1 tablespoon honey
1. Place all ingredients into the jug and secure the lid.
 2. Place onto speed HIGH. Process for 30 seconds or until smooth.
 3. Serve in tall glass.

Recipes - continued

GYM TIME

Makes: 1 large serving

- 1 banana, peeled
- 1 cup mango, roughly chopped
- 1 cup milk
- 1 tablespoon coconut oil
- 1 teaspoon chia seeds
- ½ teaspoon ground cinnamon
- ½ teaspoon ground ginger
- ½ teaspoon ground turmeric

1. Place all ingredients into the jug and secure the lid.
2. Place onto speed HIGH. Process for 30 seconds or until smooth.
3. Serve in tall glass.

DAIRY FREE BANANA SMOOTHIE

Makes: 1 serving

- 1 banana, peeled
- 1 cup almond milk
- 2 tablespoons peanut butter
- 2 teaspoons honey
- 1 teaspoon vanilla extract
- ½ teaspoon ground cinnamon

1. Place all ingredients into the jug and secure the lid.
2. Place onto speed HIGH. Process for 30 seconds or until smooth.
3. Serve in tall glass.

SALTED CARAMEL BLISS

Makes: Approx. 4 serves

- ½ cup caramel sauce
- 1 teaspoon sea salt flakes
- 6 scoops good quality vanilla ice cream
- 2 cups milk

1. Place all ingredients into the jug and secure the lid.
2. Place onto speed HIGH. Process for 30 seconds or until smooth.
3. Serve in tall glass.

EXTRA THICK CHOCOLATE THICKSHAKE

Makes: Approx. 4 servings

- ¼ cup chocolate sauce
- 4 scoops chocolate ice cream
- 2 cups chocolate milk
- Grated chocolate, to serve

1. Place all ingredients into the jug and secure the lid.
2. Place onto speed HIGH. Process for 30 seconds or until smooth.
3. Serve in tall glass.

Recipes - continued

BERRY NICE

Makes: Approx. 3 servings

2 cups frozen raspberries

1 cup milk

½ cup Greek yoghurt

1 tablespoon honey

½ teaspoon vanilla extract

1. Place all ingredients into the jug and secure the lid.
2. Place onto speed HIGH. Process for 30 seconds or until smooth.
3. Serve in tall glass.

FROZEN MARGARITA

Makes: 6-8

4 cups ice cubes

⅔ cup tequila

¼ cup Cointreau liqueur

¼ cup fresh lime juice

Lime wedges and salt, to garnish

1. Rub a cut lime around the rim of 4 margarita glasses. Place the salt onto a flat surface and dip the glasses upside down into the salt until the entire rim is coated. Chill for 5 minutes
2. Place all ingredients into the jug and secure the lid.
3. Select the ICE CRUSH function. Press START.
4. Press STOP when all ingredients are blended.
5. Serve.

FROZEN MOJITO

Makes: 4

4 cups crushed ice

1 cup white rum

½ cup simple syrup (equal parts sugar and water boiled together until sugar melts)

¼ cup fresh lime juice

24 fresh mint leaves, plus mint sprigs for garnish

1. Place all ingredients into the jug and secure the lid.
2. Select the ICE CRUSH function. Press START.
3. Press STOP when all ingredients are blended.
4. Serve.

MUDSLIDE

Makes: 4

8 scoops chocolate ice-cream

1 cup ice

1 cup pouring cream

1 cup Baileys Original Irish Cream liqueur

¼ cup chilled vodka

¼ cup Kahlua liqueur

1. Place all ingredients into the jug and secure the lid.
2. Select the ICE CRUSH function. Press START.
3. Press STOP when all ingredients are blended.
4. Serve.

Recipes - continued

PINA COLADA

Makes: 4

2 cups ice

1½ cups chilled pineapple juice

1 cup coconut milk

⅓ cup Malibu coconut liqueur

¼ cup fresh lime juice

¼ cup Midori liqueur

1. Place all ingredients into the jug and secure the lid.
2. Select the ICE CRUSH function. Press START.
3. Press STOP when all ingredients are blended.
4. Serve.

PASSIONFRUIT DAIQUIRI WITH COCONUT

Makes: 4

3 cups crushed ice

1 cup fresh lime juice

1 cup coconut cream

½ cup tequila

⅔ cup Malibu coconut liqueur

¼ cup caster sugar

⅔ cup passionfruit pulp, to serve

1. Place all ingredients into the jug and secure the lid.
2. Select the ICE CRUSH function. Press START.
3. Press STOP when all ingredients are blended.
4. Pour into glasses and top with passionfruit pulp to serve.

12 Month Replacement Guarantee

This Sunbeam product is covered by a 12 month replacement or repair warranty, which is in addition to your rights under the Australian Consumer Law (if your product was purchased in Australia) or New Zealand Consumer Guarantees Act (if your product was purchased in New Zealand).

Upon receipt of your claim, Sunbeam will seek to resolve your difficulties or, if the product is defective, advise you on how to obtain a replacement or refund.

To assist us in managing warranty claims, we recommend you register your product as soon as practicable after purchase by creating a MySunbeam account on our website and uploading a copy of your original receipt.

In order to make a claim under our warranty, you must have the original proof of purchase documentation for the product and present it when requested (if not already uploaded to our website).

Should your product develop any defect within 12 months of purchase because of faulty materials or workmanship, we will replace or repair it, at our discretion, free of charge. A product presented for repair may be replaced by a refurbished product of the same type rather than being repaired. Refurbished parts may be used to repair the product.

Our replacement or repair warranty only applies where a defect arises as a result of faulty material or workmanship during the warranty period. Your warranty does not cover misuse or negligent handling (including damage caused by failing to use the product in accordance with this instruction booklet), accidental damage, or normal wear and tear.

Your warranty does not:

- cover freight or any other costs incurred in making a claim, consumable items, accessories that by their nature and limited lifespan require periodic renewal (such as filters and seals) or any consequential loss or damage; or

- cover damage caused by:
 - power surges, power dips, voltage supply problems, or use of the product on incorrect voltage;

- servicing or modification of the product other than by Sunbeam or an authorised Sunbeam service centre;
- use of the product with other accessories, attachments, product supplies, parts or devices that do not conform to Sunbeam specifications; or
- exposure of the product to abnormally corrosive conditions; or

- extend beyond 3 months if the product is used in commercial, industrial, educational or rental applications.

The benefits given to you by our warranty are in addition to other rights and remedies under law in relation to the product.

In Australia our goods come with guarantees that cannot be excluded under the Australian Consumer Law. You are entitled to a replacement or refund for a major failure and for compensation for any other foreseeable loss or damage. You are also entitled to have the goods repaired or replaced if the goods fail to be of acceptable quality and the failure does not amount to a major failure.

Our goods also come with guarantees that cannot be excluded under the New Zealand Consumer Guarantees Act.

If your warranty claim is not accepted, we will inform you and if requested to do so by you, repair the product provided you pay the usual charges for such repair. You will also be responsible for all freight and other costs.

Should your product require repair or service after the warranty period, contact your nearest Sunbeam service centre. For a complete list of Sunbeam's service centres, visit our website or call our customer service line for advice on 1300 881 861 in Australia, or 0800 786 232 in New Zealand.

Should you experience any difficulties with your product during the warranty period, please contact our customer service line for advice on 1300 881 861 in Australia, or 0800 786 232 in New Zealand.

Australia

www.sunbeam.com.au
1300 881 861
Units 5 & 6,
13 Lord Street,
Botany NSW 2019
Australia

New Zealand

www.sunbeam.co.nz
0800 786 232
Level 6, Building 5,
Central Park,
660-670 Great South Road,
Greenlane, Auckland
New Zealand

Need help with your appliance?

Contact our customer service team or visit our website for information and tips on getting the most from your appliance.

Australia | visit www.sunbeam.com.au
phone 1300 881 861
mail Units 5 & 6, 13 Lord Street,
Botany NSW 2019 Australia.

New Zealand | visit www.sunbeam.co.nz
phone 0800 786 232
mail Level 6, Building 5, Central Park,
600-670 Great South Road,
Greenlane, Auckland, New Zealand.

Sunbeam Corporation Limited | ABN 45 000 006 771
Sunbeam Corporation is a division of GUD Holdings Limited.

Sunbeam is a registered trademark.

Made in China to Sunbeam's specification.

Due to minor changes in design or otherwise,
the product you buy may differ slightly from the one shown here.

Approved by the appropriate electrical regulatory authorities.

©Copyright Sunbeam 2014.